

RoHS THIS IS A RoHS COMPLIANT COMPONENT/PRODUCT.

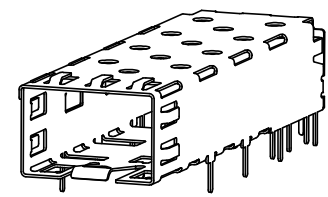

CROSS-HATCHED AREA DENOTES COMPONENT AND TRACE KEEP-OUT (EXCEPT CHASSIS GROUND)

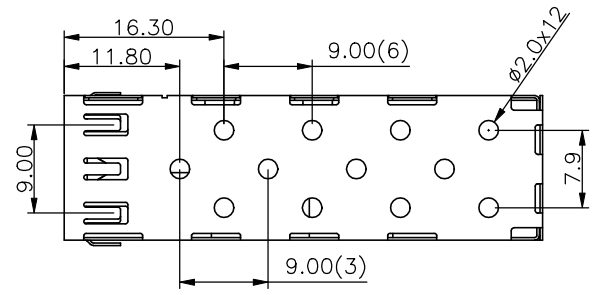
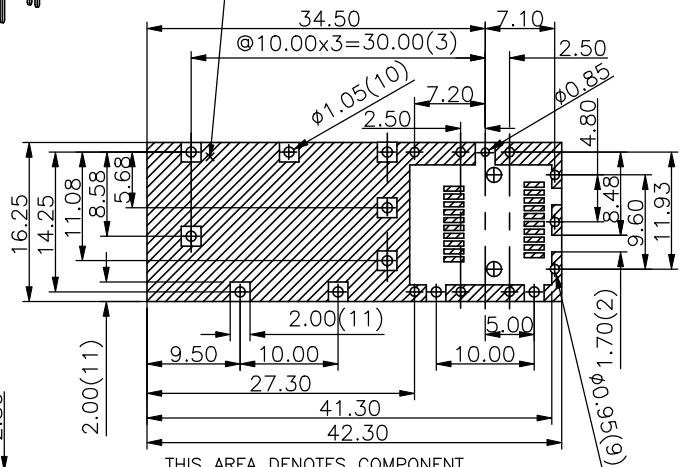

THIS AREA DENOTES COMPONENT KEEP-OUT (TRACES ALLOWED)

PCB LAYOUT (TOP VIEW)

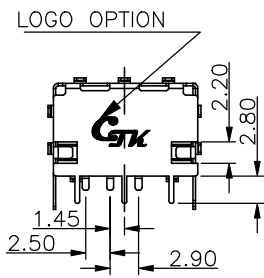
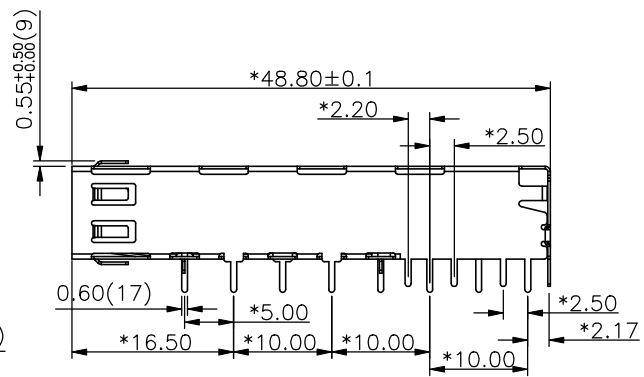
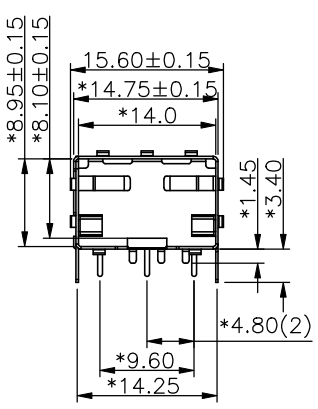

- NOTE:
- 1.MATERIAL : t=0.25mm, C5191 H&C7521 H.
 - 2.PLATED : PLATED NICKEL 30u" ~80u"
 - 3.BURR : 0.05mm MAX.
 - 4.PART NUMBER : N331X-088-X
- | | |
|---------------------|-----------------------------|
| N-NI W/O PRE TINNED | 1-CAGE, W/O LOGO(C5191 H) |
| SOLDERING PEGS | 2-CAGE, W/CTK LOGO(C5191 H) |
| T-NI W/ PRE TINNED | 3-CAGE, W/T LOGO(C5191 H) |
| SOLDERING PEGS | 4-CAGE, W/O LOGO (C7521 H) |

X0	0069000	NEW DESIGN	DORIS	122314
MARK	ECN-NO.	REVISION RECORD	DRAWN	DATE
		UNLESS OTHERWISE SPECIFIED TOLERANCE	SCALE	CHECKED
		Dimension Range	1/1	APPROVED
		X.X ±0.20	UNIT	SHEET 1/1
		X.XX ±0.15	mm	
X.XXX ±0.10	SIZE	A3		
Contact Technology Co., Ltd.		ANGLE	±5°	
Material/Plated/Notes		NAME		
SEE NOTE		1X1 SFP CAGE, FREE PRESS FIT		
Tooling No.		PART NO.	SEE NOTE	REV. A
		DOC. NO.	NN330A088	