

RoHS

THIS IS A RoHS COMPLIANT COMPONENT/PRODUCT.

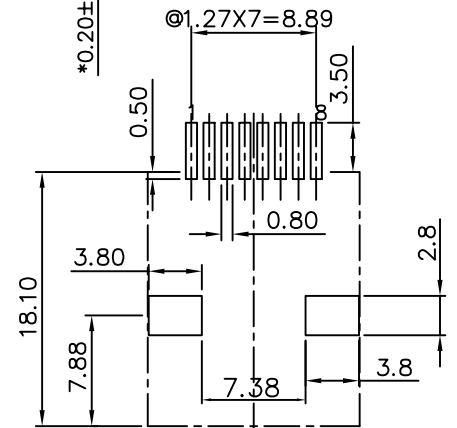
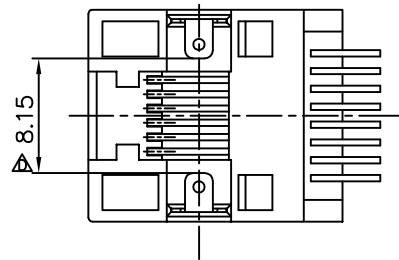
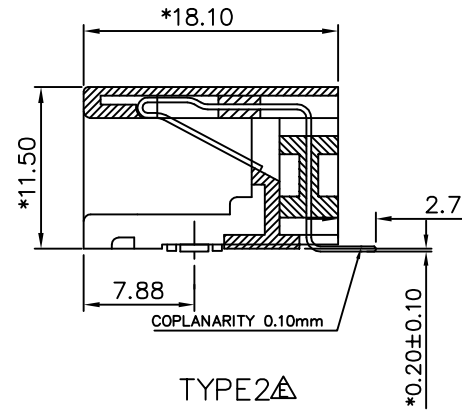
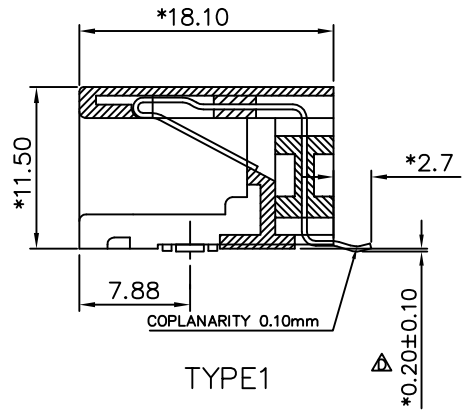
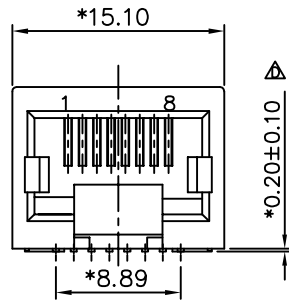

PC BOARD LAYOUT COMPONENT SIDE SHOWN

NOTES:

ELECTRICAL:

- VOLTAGE RATING : 125 VAC.
- CURRENT RATING : 1.5 AMP.
- CONTACT RESISTANCE : 35 MILLIOHMS MAX.
- INSULATION RESISTANCE: 1000 MEGOHMS MIN @ 500 VDC.
- DIELECTRIC STRENGTH : 1000 VAC 60Hz, 1MIN.

MECHANICAL:

- HOUSING MATERIAL : HIGHT TEMP UL94V-0 BK.
- CONTACT MATERIAL : PHOSPHOR BRONZE t=0.35mm.
- PLATING : GOLD PLATING OVER NICKEL.
- OPERATING LIFE : 750 CYCLES MIN.
- PCB RETENTION POST-SOLDER: 10 LBS MIN.

ENVIRONMENTAL:

- STORAGE : -40°C TO +85°C.
- OPERATION: -40°C TO +85°C.
- REFLOW SOLDERING TEMP. : 255°C~265°C (5~10 SECONDS).

MATES WITH MODULAR PLUG CONFORMING TO FCC PART 68, SUBPART F.
PART NUMBER: N331X-005-OX

- 1-3u" 2-6u"
- 3-15u" 4-30u"
- 5-50u"

- 01-8P8C HIGH TEMP. BK.TYPE1
- 02-8P2C HIGH TEMP. BK.TYPE1
- 03-8P8C HIGH TEMP. BK.TYPE2
- 04-8P2C HIGH TEMP. BK.TYPE2

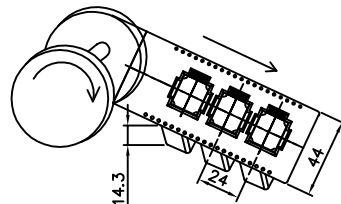

△X3		新增平脚料号	SOULE	101519'
△X2		MODIFY DRAWING	ROCK	061112'
△X1		ADD NEW P/N	YANG	010810
△X1		MODIFY DESIGN	YANG	081308
△X0	0066000	NEW DESIGN	LINGER	102706
MARK	ECN-NO.	REVISION RECORD	DRAWN	DATE

<p>Contact Technology Co., Ltd.</p>	UNLESS OTHERWISE SPECIFIED TOLERANCE		SCALE 2.5/1	CHECKED	
	Dimension Range	Tolerance	UNIT	APPROVED	
	X.X	±0.20	mm		
	X.XX	±0.15	mm		
X.XXX	±0.10	mm	SIZE A3	SHEET	1/1
ANGLE	±5°				
Material/Plated/Notes		NAME			
SEE NOTE		SIDE ENTRY 8P8C SMT JACK PEG IN			
Tooling No.	PART NO.	SEE NOTE		REV. E	
	DOC. NO.	NN330A005			